



RoboEVO
EQUIPMENT

GRAPPLE BUCKET



ENERGREEN America
1242 Nowell Dr · Augusta
GA 30901 · USA
Phone CA 510 593 3144
Phone GA 706 945 2800

info@energreenamerica.com
www.energreenamerica.com

PROFESSIONAL MACHINES AND EQUIPMENT



09/2021 - © Energreen America 2021 - All rights reserved - Photo, technical and constructive characteristics subjected to modification without reporting requirement.



TECHNICAL DATA SHEET

GRAPPLE BUCKET

Bucket with upper biting device hydraulically operated, ideal for the transfer of waste or other vegetal loose material. This material is blocked within the bucket, avoiding the fall of materials.

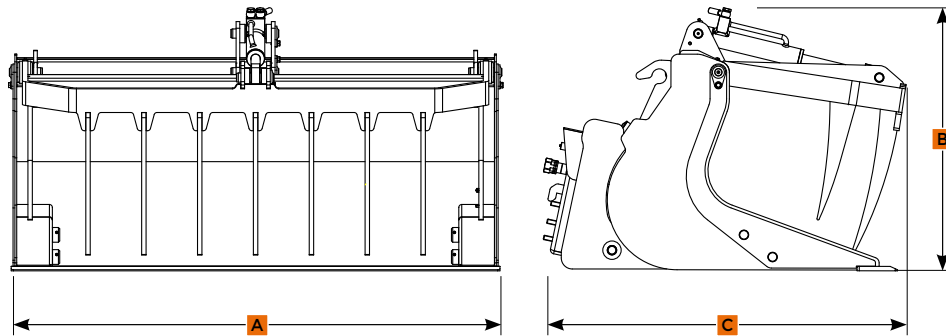

TECHNICAL DATA

(A) Width	51 in	Angle tipping bucket	47°
(B) Height	27 in	Load that can be lifted	661 lbs
(C) Depth	33 in	Bucket volume	5,2 ft ³
Discharge distance	24 in	Pressure	180 bar / 2610 psi
Max unloading height	25 in	Weight	375 lbs

