

SPEARHEAD

SNIPER MINI

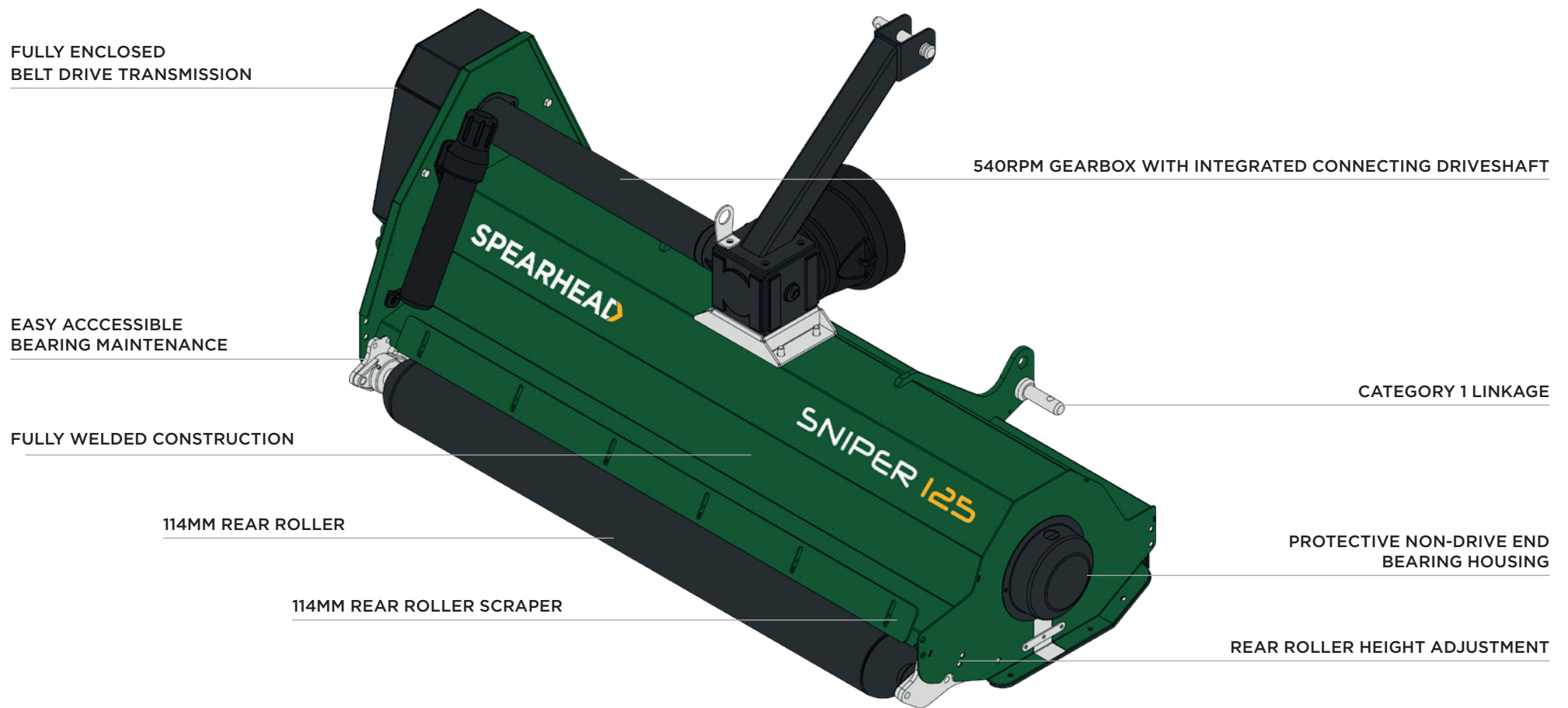

SNIPER MINI FEATURES



TRACTOR HP

13hp (12kW)



PTO SPEED

540rpm



TRANSPORT WIDTH

1.40m / 4' 8"



3-POINT LINKAGE MOUNTING



CUTTING WIDTH

1.25m / 4' 1"



FLAIL TYPE

Heavy-duty hammer flail



NUMBER OF FLAILS

26



CUTTING HEIGHT

20mm - 40mm
0.8" - 1.5"

**SNIPER
125 MINI**

SNIPER MINI THE LOW MAINTENANCE HIGH PERFORMANCE FLAIL MOWER

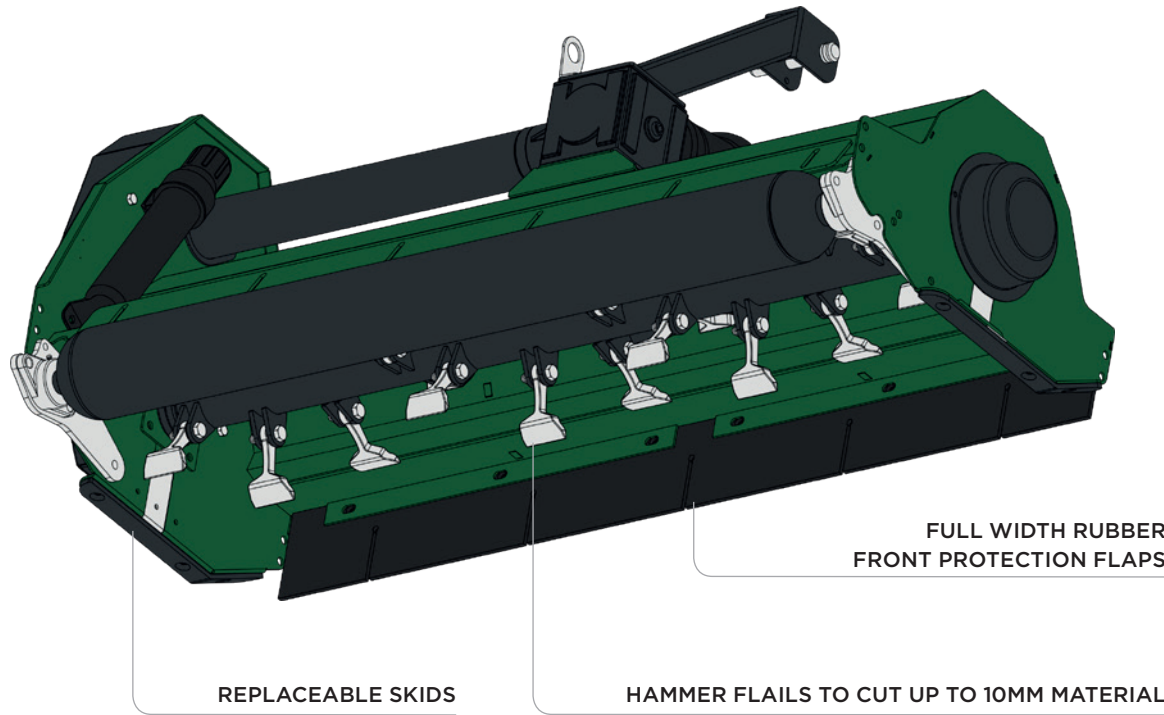

With a cutting width of 1.25m, the Sniper 125 Mini flail mower is suitable for lawns, parkland and amenity operations fitted to tractors of 15hp and greater.

This fully welded machine features a low maintenance, high speed dual belt driven transmission powered via a gearbox and enclosed connecting driveshaft to give dependable performance to each of its 26 hammer flails.

A 114mm adjustable rear roller with accompanying scraper bar safely provides a tidy and professional finish to the cut material and allows the machine to be able to offer a range of cutting heights to the operator.

CONSTRUCTION

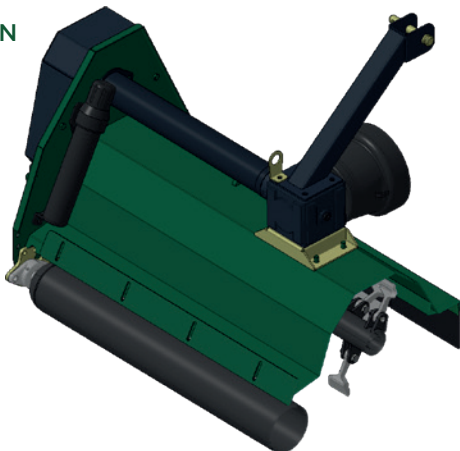

ROTOR DESIGN

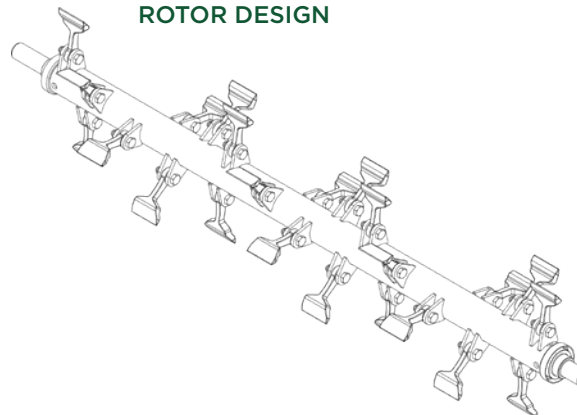

FLAIL OPTIONS



STANDARD SPECIFICATION	SNIPER 125 MINI
Machine weight	115kg (254lbs)
Hitch	Cat 1-2 with floating clevis top link
Hitch position	Rear mount only
Cutting width	1.25m (4' 1")
Overall width	1.40m (4' 8")
Overall length	0.65m (2' 2")
Cowl height	0.33m (1' 1")
Cutting height	20mm - 40mm (0.8" - 1.5")
Cutting capacity	10mm (0.4")
Recommended tractor HP	15hp (12kW)
Power take-off speed	540rpm
Gearbox	Cast iron housing with integrated enclosed connecting shaft
Input shaft	1-3/8" Z6
Gearbox lubricant	EP80-90W or GL-4 / GL-5 oil
Gearbox oil capacity	0.3 litres (0.5 pints)
Cowl construction	All welded construction
Skid construction	Replaceable bolt-on skid
Flail	Heavy-duty hammer flail
Flail quantity	26
Flail tip speed	45m/s (8858fpm)
Rotor diameter	60mm (2.4")
Roller diameter	114mm (4.5")
Number of belts	2

SPEARHEAD

📍 Station Road, Salford Priors, Evesham, Worcestershire, WR11 8SW, England 📞 +44 (0)1789 491860

✉️ enquiries@spearheadmachinery.com 📧 spearheadmachinery.com 🌐 SpearheadWorld



designed and built in
GREAT BRITAIN



Spearhead
is a member of the
Alamo Group

